

This Page Is Inserted by IFW Operations
and is not a part of the Official Record

BEST AVAILABLE IMAGES

Defective images within this document are accurate representations of the original documents submitted by the applicant.

Defects in the images may include (but are not limited to):

- BLACK BORDERS
- TEXT CUT OFF AT TOP, BOTTOM OR SIDES
- FADED TEXT
- ILLEGIBLE TEXT
- SKEWED/SLANTED IMAGES
- COLORED PHOTOS
- BLACK OR VERY BLACK AND WHITE DARK PHOTOS
- GRAY SCALE DOCUMENTS
- BLANK PAGES

IMAGES ARE BEST AVAILABLE COPY.

**As rescanning documents *will not* correct images,
please do not report the images to the
Image Problem Mailbox.**

(12) UK Patent Application (19) GB (11) 2 347 446 (13) A

(43) Date of Printing by UK Office 06.09.2000

(21) Application No 0000487.9

(22) Date of Filing 13.07.1998

(30) Priority Data

(31) 9714651.8 (32) 12.07.1997 (33) GB

(86) International Application Data

PCT/GB98/02066 En 13.07.1998

(87) International Publication Data

WO99/02818 En 21.01.1999

(51) INT CL⁷

E21B 43/10 33/10

(52) UK CL (Edition R)

E1F FAC FAC9

(56) Documents Cited by ISA

WO 94/25688 A US 3744091 A US 3669190 A

US 3489220 A US 3353599 A

METCALFE P-PETROLEUM ENGINEER

INTERNATIONAL, vol.69, no.10 October 1996, pages

60 - 63, XP000684479

(58) Field of Search by ISA

INT CL⁶ E21B

(71) Applicant(s)

Weatherford/Lamb, Inc
(Incorporated in USA - Delaware)
c/o CSC - The United States Corporation Company,
1013 Centre Road, Wilmington, Delaware 19806,
United States of America

(74) Agent and/or Address for Service

Cruikshank & Fairweather
19 Royal Exchange Square, GLASGOW, G1 3AE,
United Kingdom

(72) Inventor(s)

Paul David Metcalfe

(54) Abstract Title

Downhole tubing

(57) There is provided a downhole tubing sealing system (10) comprising a radially expandable slotted tubular body (16) carrying deformable material (22) on the exterior thereof; and a seal member (26) for location within the tubular body and for engaging an inner surface of said body. There is further provided a method of sealing a portion of a downhole bore, the method comprising locating a radially expandable slotted tubular body (16) carrying deformable material (22) on the exterior thereof in a bore, expanding the body radially into contact with the bore wall, and locating a seal member (26) within the body and radially extending the seal member to engage an inner surface of the body, so sealing a portion of the downhole bore.

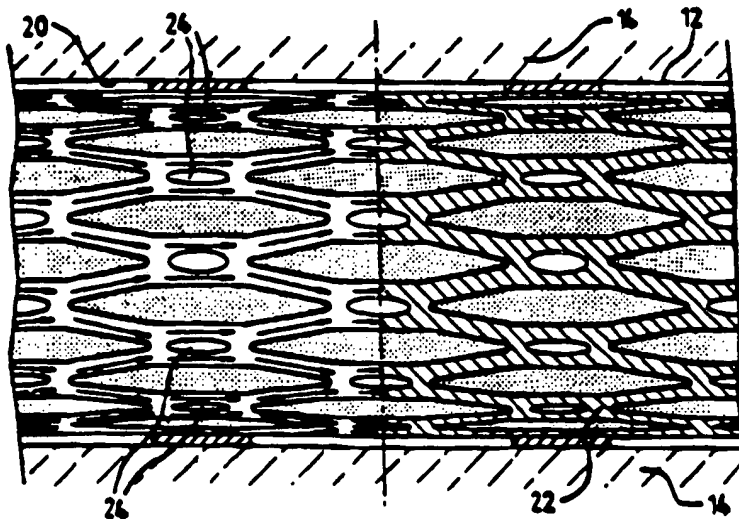

GB 2 347 446 A



INTERNATIONAL APPLICATION PUBLISHED UNDER THE PATENT COOPERATION TREATY (PCT)

<p>(51) International Patent Classification ⁶ : E21B 43/10, 33/10</p>	<p>A1</p>	<p>(11) International Publication Number: WO 99/02818 (43) International Publication Date: 21 January 1999 (21.01.99)</p>
<p>(21) International Application Number: PCT/GB98/02066 (22) International Filing Date: 13 July 1998 (13.07.98) (30) Priority Data: 9714651.8 12 July 1997 (12.07.97) GB (71) Applicant (for all designated States except US): PETROLINE WELLSYSTEMS LIMITED [GB/GB]; Offshore Technology Park, Claymore Drive, Bridge of Don, Aberdeen AB23 8GD (GB). (72) Inventor; and (75) Inventor/Applicant (for US only): METCALFE, Paul, David [GB/GB]; North Wing, Bucklerburn Steading, Peterculter AB14 0NP (GB). (74) Agents: McCALLUM, William, Potter et al.; Cruikshank & Fairweather, 19 Royal Exchange Square, Glasgow G1 3AE (GB).</p>	<p>(81) Designated States: AL, AM, AT, AU, AZ, BA, BB, BG, BR, BY, CA, CH, CN, CU, CZ, DE, DK, EE, ES, FI, GB, GE, GH, GM, HR, HU, ID, IL, IS, JP, KE, KG, KP, KR, KZ, LC, LK, LR, LS, LT, LU, LV, MD, MG, MK, MN, MW, MX, NO, NZ, PL, PT, RO, RU, SD, SE, SG, SI, SK, SL, TJ, TM, TR, TT, UA, UG, US, UZ, VN, YU, ZW, ARIPO patent (GH, GM, KE, LS, MW, SD, SZ, UG, ZW), Eurasian patent (AM, AZ, BY, KG, KZ, MD, RU, TJ, TM), European patent (AT, BE, CH, CY, DE, DK, ES, FI, FR, GB, GR, IE, IT, LU, MC, NL, PT, SE), OAPI patent (BF, BJ, CF, CG, CI, CM, GA, GN, GW, ML, MR, NE, SN, TD, TG). Published With international search report.</p>	

(54) Title: DOWNHOLE TUBING

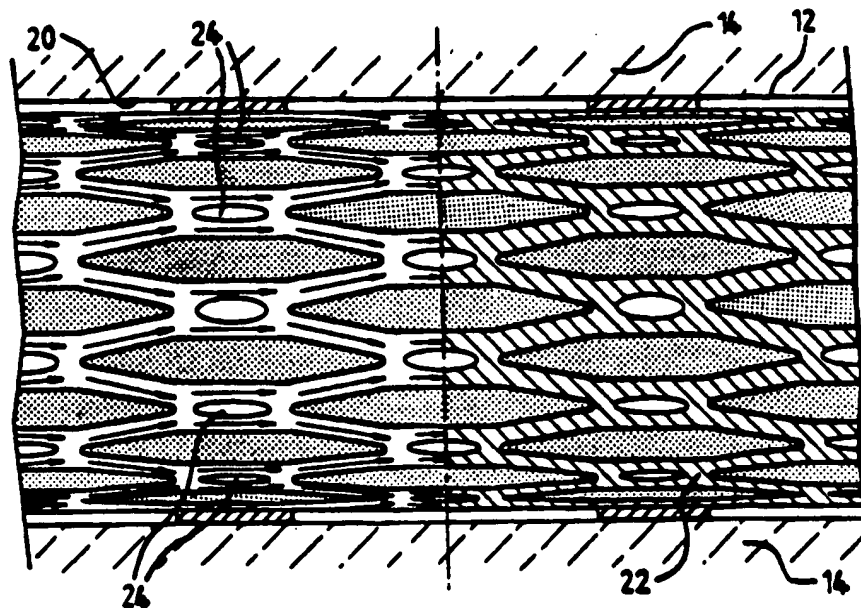

(57) Abstract

There is provided a downhole tubing sealing system (10) comprising a radially expandable slotted tubular body (16) carrying deformable material (22) on the exterior thereof; and a seal member (26) for location within the tubular body and for engaging an inner surface of said body. There is further provided a method of sealing a portion of a downhole bore, the method comprising locating a radially expandable slotted tubular body (16) carrying deformable material (22) on the exterior thereof in a bore, expanding the body radially into contact with the bore wall, and locating a seal member (26) within the body and radially extending the seal member to engage an inner surface of the body, so sealing a portion of the downhole bore.

FOR THE PURPOSES OF INFORMATION ONLY

Codes used to identify States party to the PCT on the front pages of pamphlets publishing international applications under the PCT.

AL	Albania	ES	Spain	LS	Lesotho	SI	Slovenia
AM	Armenia	FI	Finland	LT	Lithuania	SK	Slovakia
AT	Austria	FR	France	LU	Luxembourg	SN	Senegal
AU	Australia	GA	Gabon	LV	Latvia	SZ	Swaziland
AZ	Azerbaijan	GB	United Kingdom	MC	Monaco	TD	Chad
BA	Bosnia and Herzegovina	GE	Georgia	MD	Republic of Moldova	TG	Togo
BB	Barbados	GH	Ghana	MG	Madagascar	TJ	Tajikistan
BE	Belgium	GN	Guinea	MK	The former Yugoslav Republic of Macedonia	TM	Turkmenistan
BF	Burkina Faso	GR	Greece			TR	Turkey
BG	Bulgaria	HU	Hungary	ML	Mali	TT	Trinidad and Tobago
BJ	Benin	IE	Ireland	MN	Mongolia	UA	Ukraine
BR	Brazil	IL	Israel	MR	Mauritania	UG	Uganda
BY	Belarus	IS	Iceland	MW	Malawi	US	United States of America
CA	Canada	IT	Italy	MX	Mexico	UZ	Uzbekistan
CF	Central African Republic	JP	Japan	NE	Niger	VN	Viet Nam
CG	Congo	KE	Kenya	NL	Netherlands	YU	Yugoslavia
CH	Switzerland	KG	Kyrgyzstan	NO	Norway	ZW	Zimbabwe
CI	Côte d'Ivoire	KP	Democratic People's Republic of Korea	NZ	New Zealand		
CM	Cameroon		Republic of Korea	PL	Poland		
CN	China	KR	Republic of Korea	PT	Portugal		
CU	Cuba	KZ	Kazakhstan	RO	Romania		
CZ	Czech Republic	LC	Saint Lucia	RU	Russian Federation		
DE	Germany	LI	Liechtenstein	SD	Sudan		
DD	Demerara	LR	Liberia	SE	Sweden		
DI	Dominica	LV	Latvia	SG	Singapore		

DOWNHOLE TUBING

This invention relates to downhole tubing, a downhole tubing sealing system, and to elements of such a system. The invention also relates to a method of lining a bore and to a method for sealing downhole tubing.

5 In oil and gas extraction operations, a bore is drilled through the earth to intersect a hydrocarbon-bearing formation which forms the hydrocarbon reservoir, allowing oil and gas from the reservoir to be transported to the surface. The bore intersecting the reservoir is typically lined with steel casing which is cemented in the
10 bore. A perforating gun is then lowered into the bore and detonated to form perforations which extend through the casing and the cement and into the formation. Typically, sets of perforations are provided at intervals along the casing, and the perforated casing may extend for several
15 thousand metres through the formation. To control the flow of oil from the formation inflatable packers may be provided to isolate selected sets of perforations and thus isolate the corresponding portions of the formation.

20 It has recently been proposed that such cemented and perforated casing be replaced by expandable slotted tubing, such as described in WO93\25800 (Shell Internationale Research Maatschappij B.V.). Such tubing comprises lengths of tube which have been machined to create a large number
25 of overlapping longitudinal slots. The tube is radially expanded, while downhole, into contact with the bore wall,

the slots extending to create diamond-shaped apertures. The expanded tube thus provides support for the bore wall while allowing oil to flow into the bore through the extended slots.

5 It is among the objectives of embodiments of the present invention to provide a system which allows a section of bore wall lined with such expanded tubing to be sealed or isolated, and thus facilitate control of the flow of oil from a hydrocarbon reservoir.

10 According to one aspect of the present invention there is provided downhole tubing comprising a radially expandable slotted tubular body carrying deformable material on the exterior thereof.

15 According to a further aspect of the present invention there is provided a downhole tubing sealing system comprising a radially expandable slotted tubular body carrying deformable material on the exterior thereof, and a seal member for location within the body and for engaging an inner surface of the body.

20 In use, the tubular body is located in a bore and expanded radially into contact with the bore wall. The presence of the deformable material on the exterior of the body ensures that full contact is achieved between the outer surface of the body and the bore wall. The sealing member is then activated to engage the inner surface of the
25 body and provides a sealing contact therewith. The length of the seal member and/or the location of the seal member in the body is selected such that none of the slots in the

body extend beyond both ends of the seal member; otherwise, fluid would be able to flow around the seal member by passing along the slots.

According to another aspect of the present invention there is provided a method of isolating a portion of a downhole bore, the method comprising the steps of:

providing a radially expandable slotted tubular body carrying deformable material on the exterior thereof;

locating the body in a bore and expanding the body radially into contact with the bore wall; and

locating a seal member within the body and radially extending the member to engage an inner surface of the body.

As used herein the terms "slots" is intended to encompass any holes or apertures which facilitate expansion of the body, including bores, slots or weakened areas which initially only extend part way through the body.

These aspects of the invention permit the complete sealing of a bore lined with expanded slotted tubing. Conventional expanded slotted metal tubing does not achieve a fluid-tight metal-to-rock contact: because the outer surface of the tubing tends to retain its original curvature, that is the curvature of the unexpanded tubing, not all of the outer surface contacts the bore wall following expansion. With the inner surface sealed, for example by a packer, there remains a small area S-shaped leak path between the tubing and the bore wall where the tubing is not in contact with the wall; this leak path may

account for around 0.5% of the cross sectional area of a bore. However, with the present invention the deformable material on the outer surface of the body allows complete contact between the body and the bore wall and eliminates this leak path.

Preferably, the deformable material is an elastomer. Of course the deformable material will be selected to withstand handling and the conditions experienced downhole, for example the selected material preferably bonds to the body outer surface sufficiently to prevent erosion or degradation during installation, withstands the elevated temperatures experienced downhole (typically 130 - 180°C), and is resistant to crude oils, brines, acids and other fluids likely to be encountered downhole.

According to a further aspect of the present invention there is provided a method of lining a downhole bore, the method comprising the steps of:

providing a radially expandable slotted tubular body carrying deformable material on the exterior thereof; and locating the body in a bore and expanding the body radially into contact with the bore wall.

These and other aspects of the present invention will now be described, by way of example, with reference to the accompanying drawings, in which:

Figure 1 is a schematic sectional view of a downhole sealing system in accordance with an embodiment of the present invention, shown in a bore;

Figure 2 is an enlarged sectional view on line 2 - 2

of Figure 1; and

Figure 3 is an enlarged side view of the tubing of system of Figure 1, one half of the Figure illustrating the effect of the absence of a deformable material coating as provided in embodiments of the present invention.

The drawings illustrate a downhole tubing sealing system 10 in accordance with an embodiment of the present invention. The system 10 is shown, in Figure 1 of the drawings, in a drilled horizontal bore 12 which intersects an oil bearing formation or reservoir 14.

The system 10 includes tubing 16, similar to that as described in W093\25800 (Shell Internationale Research Maatschappij B.V.), which includes a large number of overlapping longitudinal slots 18. The tubing 16 is run into the bore 12 in unexpanded configuration and a mandrel then pushed up or pulled through the tubing 16 to expand the tubing radially outwards. The expansion is accommodated by the extension of the slots 18 to form the diamond shaped apertures as illustrated in Figure 3 of the drawings. As may be seen in Figure 2 of the drawings, the tubing 16 is expanded into contact with the bore wall 22, and thus provides support for the bore wall 20 while allowing oil to flow from the reservoir through the expanded slots 18.

The tubing 16 is formed of an appropriate metal, typically steel, and carries an external coating of a deformable material in the form of an elastomer 22. The provision of the elastomer coating allows the outer surface

of the tubing 16 to form a sealing contact with the bore wall 20, as described below.

On expansion of the tubing 16, the metal outer surface of the tubing tends to retain its original curvature, that is the curvature of the unexpanded tubing, as may be seen from Figure 2. As a result, in the absence of an elastomer coating 22, not all of the outer surface of the tubing would contact the bore wall 22 following expansion; metal-to-rock contact would only be achieved at the contact points 24 as indicated in Figures 2 and 3. Thus, it may be seen that, in the absence of the elastomer coating, a small area S-shaped leak path would remain between the tubing and the bore wall where the tubing was not in contact with the wall. However, in the present invention, differential compression of the elastomer coating 22 ensures that there is an elastomer-to-rock contact around the circumference of the tubing (though of course not at the slots 18).

In the illustrated example the reservoir 14 has been isolated from the bore 12 by providing a packer 26 within the tubing 16, the packer providing a sealing contact with the interior of the tubing 16 over the length of the intersection of the bore 12 with the reservoir 14. The packer 26 is mounted on a tube 28 which allows fluid to flow past the isolated reservoir 14.

It will be apparent to those of skill in the art that the above-described embodiment provides numerous advantages over conventional cemented and perforated casing systems, and also other methods of sealing expanded slotted tubing.

such as providing an external isolation sleeve on the tubing. With the present invention, the whole length of the tubing may contribute to flow as all of the slots in the tubing are normally opened. Further, the internal sealing member or packer may be provided at any location in the tubing, and is thus adaptable to deal with any situation or problems that may arise in a bore.

It will also be clear to those of skill in the art that the above-described embodiment is merely exemplary of the present invention, and that various modifications and improvements may be made thereto, without departing from the scope of the present invention.

CLAIMS

1. Downhole tubing comprising a radially expandable slotted tubular body carrying deformable material on the exterior thereof.
- 5 2. The downhole tubing of claim 1 wherein said deformable material is an elastomer.
3. The downhole tubing of claim 2 wherein said elastomer is selected to be resistant to high temperatures, and to crude oils, brines, acids, and other degradative fluids
10 encountered downhole.
4. A downhole tubing sealing system comprising the downhole tubing of claims 1 to 3, and a seal member for location within said body and for engaging an inner surface of said body.
- 15 5. A method of isolating a portion of a downhole bore, the method comprising the steps of:
 - providing a radially expandable slotted tubular body carrying deformable material on the exterior thereof;
 - locating said body in a bore and expanding said body
20 radially into contact with the bore wall; and
 - locating a seal member within said body, and radially extending said member to engage an inner surface of said

body.

6. A method of lining a downhole bore, the method comprising the steps of:

- 5 providing a radially expandable slotted tubular body carrying deformable material on the exterior thereof; and
locating said body in a bore and expanding said body radially into contact with the bore wall.

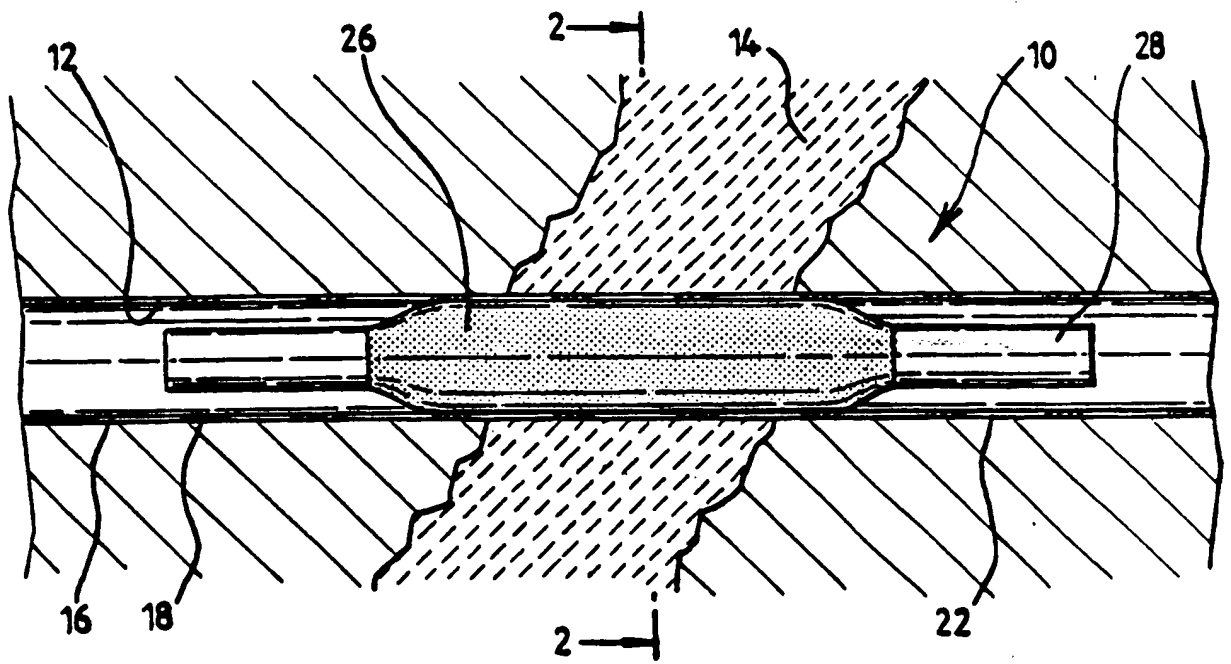

FIG. 1

2/2

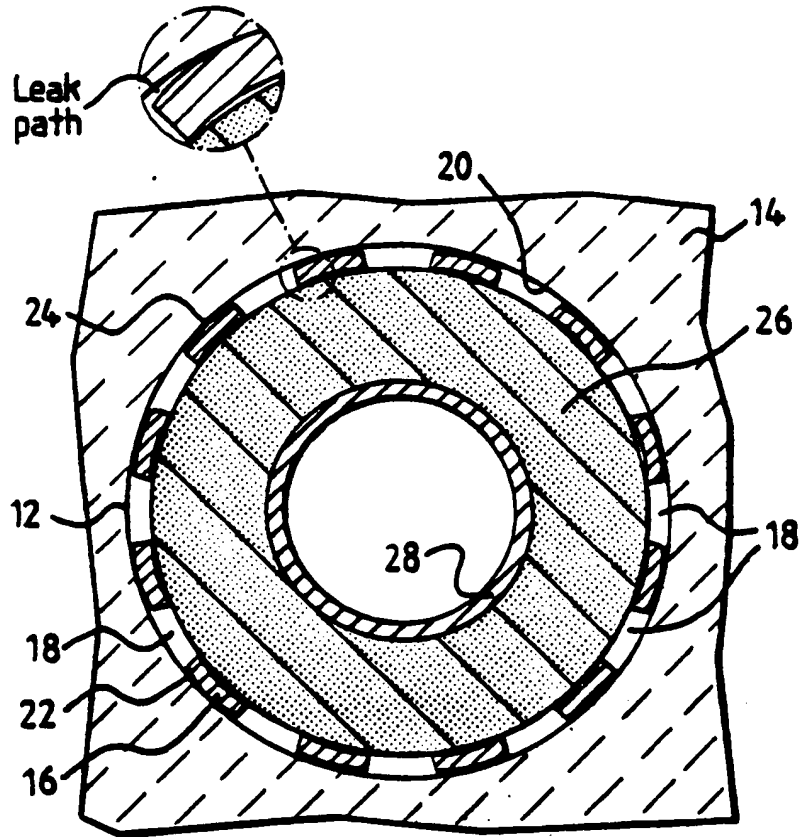

FIG. 2

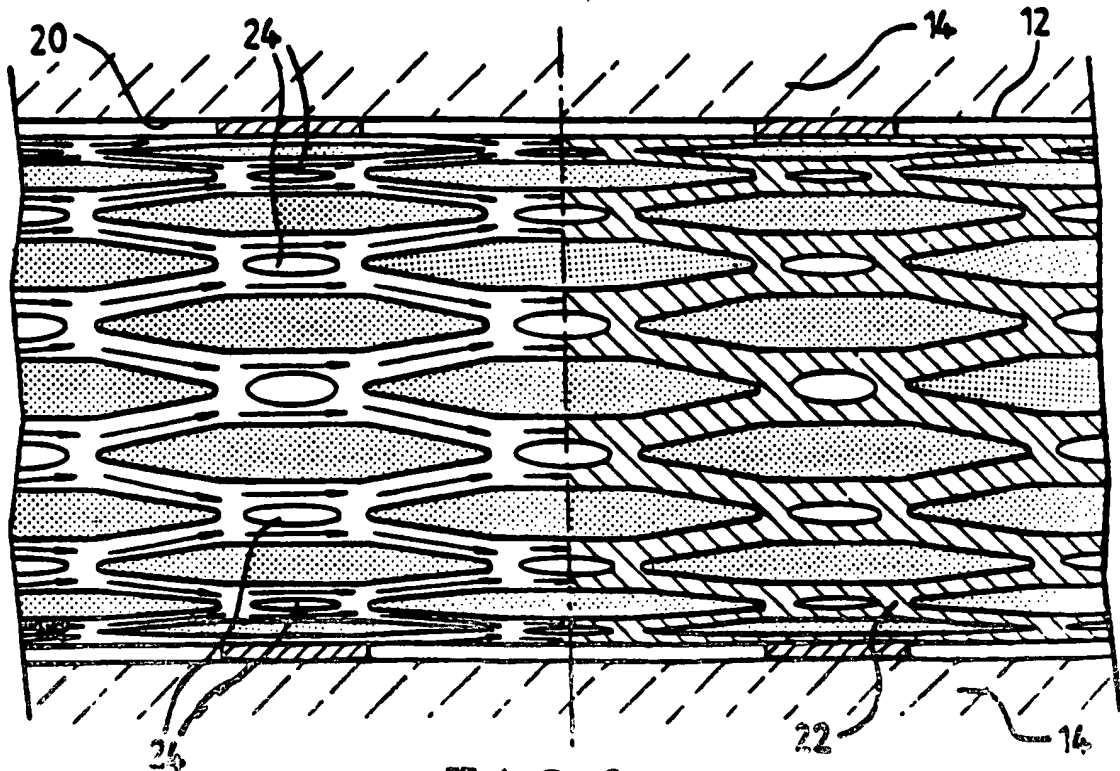

FIG. 3

INTERNATIONAL SEARCH REPORT

National Application No
PCT/GB 98/02066

A. CLASSIFICATION OF SUBJECT MATTER
IPC 6 E21B43/10 E21B33/10

According to International Patent Classification (IPC) or to both national classification and IPC

B. FIELDS SEARCHED
Minimum documentation searched (classification system followed by classification symbols)
IPC 6 E21B

Documentation searched other than minimum documentation to the extent that such documents are included in the fields searched

Electronic data base consulted during the international search (name of data base and, where practical, search terms used)

C. DOCUMENTS CONSIDERED TO BE RELEVANT

Category	Citation of document, with indication, where appropriate, of the relevant passages	Relevant to claim No.
X	WO 94 25655 A (DRILLFLEX) 10 November 1994 see page 5, line 30 - page 6, line 21 see page 7, line 25 - page 8, line 5 see page 9, line 26 - line 31	1-3,6
A	US 3 746 091 A (OWEN ET AL.) 17 July 1973 see column 7, line 7 - line 16	1
A	US 3 489 220 A (KINLEY) 13 January 1970 see column 2, line 36 - line 55 see column 6, line 70 - line 75	1
A	US 3 353 599 A (SWIFT) 21 November 1967 see column 4, line 71 - column 5, line 30	1
A	US 3 669 190 A (SIZER ET AL.) 13 June 1972 see abstract	4,5
	-/-	

Further documents are listed in the continuation of box C. Patent family members are listed in annex.

Special categories of cited documents:

- "A" document defining the general state of the art which is not considered to be of particular relevance
- "E" earlier document but published on or after the international filing date
- "L" document which may throw doubts on priority claim(s) or which is cited to establish the publication date of another citation or other special reason (as specified)
- "O" document referring to an oral disclosure, use, exhibition or other means
- "P" document published prior to the international filing date but later than the priority date claimed
- "T" later document published after the international filing date or priority date and not in conflict with the application but cited to understand the principle or theory underlying the invention
- "X" document of particular relevance: the claimed invention cannot be considered novel or cannot be considered to involve an inventive step when the document is taken alone
- "Y" document of particular relevance: the claimed invention cannot be considered to involve an inventive step when the document is combined with one or more other such documents, such combination being obvious to a person skilled in the art
- "Z" document member of the same patent family

Date of the actual completion of the international search	Date of mailing of the international search report
19 October 1998	23/10/1998

Name and mailing address of the ISA European Patent Office, P.O. 5818 Patentstein 2 NL - 2280 HV Rijswijk Tel. (+31-70) 340-3110, Telex 31 651 epo nl, Fax: (+31-70) 340-3118	Authorized officer Rampelmann, K
---	---

INTERNATIONAL SEARCH REPORT

International Application No
PCT/GB 98/02066

C.(Continuation) DOCUMENTS CONSIDERED TO BE RELEVANT

Category	Citation of document, with indication, where appropriate, of the relevant passages	Relevant to claim No.
A	METCALFE P: "EXPANDABLE SLOTTED TUBES OFFER WELL DESIGN BENEFITS" PETROLEUM ENGINEER INTERNATIONAL, vol. 69, no. 10, October 1996, pages 60-63, XP000684479 see the whole document -----	1,6

INTERNATIONAL SEARCH REPORT

Information on patent family members

International Application No

PCT/G8 98/02066

Patent document cited in search report	A	Publication date	Patent family member(s)	Publication date
WO 9425655	A	10-11-1994	FR 2704898 A AU 673261 B AU 6660194 A CA 2162035 A CN 1122619 A DE 69412252 D EP 0698136 A JP 8509532 T NO 954299 A US 5695008 A	10-11-1994 31-10-1996 21-11-1994 10-11-1994 15-05-1996 10-09-1998 28-02-1996 08-10-1996 07-12-1995 09-12-1997
US 3746091	A	17-07-1973	NONE	
US 3489220	A	13-01-1970	NONE	
US 3353599	A	21-11-1967	NONE	
US 3669190	A	13-06-1972	NONE	